

**Performance Analysis of Vinyl Ester Polymer Composites Reinforced with
Banana Fibers**Dr M Shanmugaraja¹, T. Tharoon²¹ Professor, Department of Automobile Engineering, SNS College of Technology, Coimbatore-35,
Tamilnadu, India.² Project Assistant, Department of Mechanical Engineering, Coimbatore Institute of Engineering and Technology,
Coimbatore-641109, Tamilnadu, India.

Abstract: - Today's world is in much need of innovations in quality of materials to prevent material failures in components. To fulfil that a special type of materials known as composite materials are introduced. The composite materials have improved in properties when compared to conventional materials. A proposal is made in this paper to work with Fiber reinforced composites with Vinyl ester as matrix and untreated Banana fibers as reinforcement to investigate the properties enhanced out from the Composite materials. The usage of natural fiber reinforced composites may innovate for various new compositions, where the properties are studied by performing various mechanical tests. Moreover, the banana fibers are well available around everywhere. The resin vinyl ester, generally is highly versatile, with the strength higher than polyester and is being cheaper than the other resins. The composite materials were fabricated using compression molding technique in order to have a quick action and to have uniform fiber distribution. The tests like tensile test, water absorption test, and Impact test are conducted to study out the properties.

Keywords:- Analysis, polymer, composite, banana fiber, Vinyl easter

I. INTRODUCTION

Natural fiber composites are becoming increasingly popular in innovating various new composition of materials and to replace the currently using materials to form as a new innovative ones. More recently, they have been attracting attention as a viable and ecologically friendly substitute for mineral and synthetic fiber composites. The mechanical properties of these natural fiber reinforcements will attain nearly to that of synthetics. So, the using of natural fiber reinforced composites lead to decrease the weight of the components, and it reduces the cost too. Moreover, they are recyclable, biodegradable, non-abrasive to machinery, and pose little health risk upon inhalation. These versatile properties paves way to research in the natural fiber reinforced composites for various applications. The selected resin is Vinyl Ester resin since, they have better resin-infusion properties. Moreover, the vinyl ester resins are capable of combining the properties of epoxy resins with the Polyester resins, and can be used at the places of better corrosion resistance, and higher strength properties. The best corrosion resistance of Thermoset polymer based Vinyl Esters gives a lot more opportunities to usage of components in a very challenging marine environment components, such as boat hulls, and these are very useful in preparing the chemical resistant components such as FRP tanks, Nuclear devices etc. The less sensitive properties of the vinyl ester to ambient conditions also results in providing their compositions in marine environments. These versatile properties of vinyl ester may favor to generate a lot of innovations in a composite industry. The vinyl ester molecule also features fewer ester groups. These ester groups are susceptible to water degradation by hydrolysis which means that vinyl esters exhibit better resistance to water and many other chemicals than their polyester counterparts. The combination of these materials will results in better results for applying in various industries particularly Automotive, Aerospace and marine industries. The usage of composites in automotive industries results in reduction in weight of the composites and it will lead to better fuel efficiency of the vehicles. Like these, there are many more advantages to innovate in the composite materials. A composite material is one which is formed by combining two or more materials of different physical and chemical properties to form a material of superior properties for the composite materials. Composite generally consists of two phases-Matrix phase and Reinforcement phase. Matrix material is considered as the basic resins such as epoxy, vinyl ester, and polyester. The Reinforcement phase includes the fibers which may be natural or artificial. The matrix phase provides a complete support for reinforcement. Basically, the properties of newly formed composite material are based on the properties of the reinforced fibers. The fibers are used because, the fibers are embedded into the matrix in a certain direction, and the result is an anisotropic structure in which the alignment of the material affects its strength. The composite material with polymers in the reinforced phase is known as Polymer matrix composites. In general view, the properties of the polymers are inadequate to many applications, due to their low strength and stiffness compared to Metal and Ceramic matrix phases. There raises a need of introducing new reinforcements with the polymers to improve strength. Thus, there evolved the development of this type of composite materials.

II. LITERATURE REVIEW

Literature review has been conducted through books and international journals from various publications. Based on certain keys like PMC compositions, Testing methods, PMC properties, fiber orientations and Fabrication process involved. The literature review helped to propose a methodology based on the above keys referred. The reference of several journals and publications under this key is used to study about the usage of different compositions of Polymers with reinforcements. The study shows that the polymers were mostly reinforced with the artificial fibers such as glass, carbon etc. to increase to superior properties of the composite materials [1, 2]. But, it leads to high cost, when using artificial fibers. For medium strength applications, it lead to unnecessary costs. Thus, this literature review says to choose the PMC compositions based on the properties involved [5, 6]. The selection of fiber should be more important for PMC composition selection. Since, the artificial fibers are found to be resulting in unnecessary costs, the natural fibers facilitate in making lightweight compositions with low cost and appreciable properties. The various types of natural fibers has been used till now and several studies were taken. In that case, the natural fibers has many more advantages such as easy handling, less toxic, easily biodegradable, easy availability etc. The natural fibers has been found to be reinforced with various polymers to let out with new compositions of PMCs [8]. A literature review is taken based on the Fiber orientation. Generally, it is found that the different orientation of fibers can lead to various changes in properties of the composite materials. Thus, a study based on fiber orientations show that the fibers can be reinforced with many types of orientations such as Angular, continuation of fibers, based on fiber length and based on weight fraction. These orientations can also results in giving variation in several particular properties of the materials. The literature review showed that the composites has been prepared using single types of orientations to compare the study. The usage of natural fibers in this methodology is found to be minimal. The polymers can be easily reinforced with the fibers with several fabrication techniques [7, 4]. The most of the fibers were reinforced with polymers by using hand lay-up technique, since it is the simplest method and requires low tooling cost. But, there were also cases that PMC were prepared using advanced methods such as Compression molding and Vacuum Impregnation. The advantages if using compression molding technique is that the materials can be easily cured at a relative temperatures and even quicker. But, for natural fibers, vacuum impregnation is not preferred, since it may again lead to unnecessary cost. Thus, the fabrication method should favour the cost of the material too [9]. The fabrication method is selected on the basis of handling of resins and fibers. The Polymer matrix compositions has varied testing methods available and these were undertaken to study the properties of various compositions based on the applications used [11]. The testing methods were undertaken according to the ASTM standards. The resin selected is Vinyl-Ester. Vinyl-Ester resin have a perfect resin-infusion properties. It combines excellent mechanical properties with very good corrosion resistance. And also, it have good delamination resistance and resistance to rot, such that it may be applied to various marine based applications, in order to have a good corrosion resistance and appreciable strength. Currently, the Vinyl Ester resins are becoming heavily important for combining with different Fiber Reinforcements. They combine the excellent mechanical, chemical and solvent resistance properties of epoxy resins with the properties found in the unsaturated polyester resins [10]. The fiber selected is Banana Fiber. The banana fibers have very strong properties, and high stiffness when compared with other natural fibers. Moreover, this fibers are very naturally available in abundant forms. Banana Fiber is widely appreciated for its characteristics such as high strength, strong moisture absorption, good luster, light weight, fast moisture absorption and release. So, there arises a chance to get bonded with the resins with appreciable properties. Apart from this, the usage of a natural fibers lead to reduce the weight of the materials invariably high. This reduces the cost of the materials at higher level. The combinations of this polymer and fibers may lead to reduced weight with appreciable strength properties, and reduced cost. It can be used in various structural applications based on the results of the properties.

III. PROPOSED METHODOLOGY

The orientation for reinforcement of the fibers was selected on the basis of fiber lengths. Since, the properties of the material vary with the fiber length, this methodology was chosen. The actual variation of the properties of the composite materials was not yet determined. So, we made a procedure to use two types of fibers .i.e., with smaller fiber length and with the longer fiber length along with different weight fractions of fiber.

IV. EMPIRICAL INVESTIGATION

A. Purchase of raw materials

The polymer Vinyl ester were purchased on the brand VBR from Covai Seenu and Company, Coimbatore and the Banana fibers were purchased from Eco green unit, Coimbatore.

B. Material preparation

The selected fabrication method is compression molding technique shown in figure 1. It requires minimal preheating temperature with low pressurizing factors.

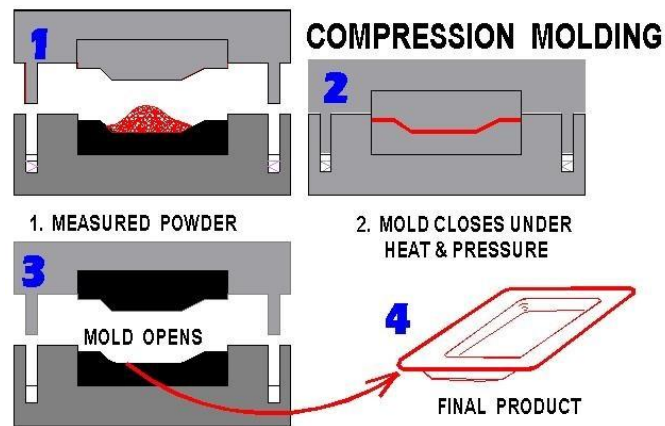

Figure 1 Compression Moulding

During this technique, initially the fibers have been cut according to the specified length as shown in figure 2. Then, they are weighed to determine the proposed weight fractions of 10% and 20% respectively. These two types of fractions are made up with two types of fiber lengths and is kept off. Now, the vinyl ester resin is taken in a beaker and is mixed thoroughly with catalyst, accelerator and promoter respectively in the same order to balance remaining weight fraction.



Figure 2 Banana fiber

Then, the die to be used in the Compression molding apparatus is surfaced with a release wax, which is applied thoroughly in order to have a better surface finish, and to have the separation of composite materials with the surface of the die. The prepared fibers are arranged neatly on the die as shown in figure 3, to have a uniform distribution of fibers in all the compositions. The prepared resin is poured on the arranged fibers on the die to make sure of spreading of resins in all the parts of fibers uniformly and thoroughly. Then, the arranged fibers and resins are closed by the upper die and is inserted into the fixed parts of the mold cavity.

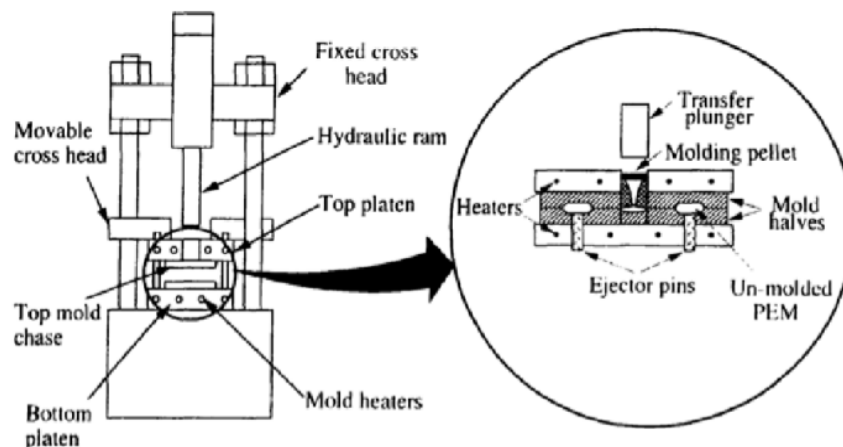

Figure 3 Schematic diagram of Compression Moulding

Then, it is preheated to a temperature of 150°C at a pressure of 10 MPa. The preheating process is carried out for nearly 30 minutes. The pressure is exerted to squeeze the resin, such that it fills the whole of the mold cavity. The temperature of 150°C is required in order to have a better curing of the resin. The plastication stage is occurred during this step where the force increases rapidly as the polymer feed is compressed and heated. After the curing time is out, the die is taken out, and the dies are opened carefully with a thermo resisting material, since the die plates will be at very high temperatures. The material part is removed from the die with the help of ejector pins, and the material is now cooled down at the room temperature to maintain its shape and accurate dimensions, throughout the material once it gets hardened. The fibers have been properly set by placing heavy wooden blocks on it in order to maintain its proper shape and hardness at the room temperature for nearly 10-15 minutes.

C. Fabrication of Specimen

During this research, two types of composites with different volume fraction of banana fiber and different fiber length has been fabricated as given in table 1.

Table 1 Specification of Fiber

Specifications	20 mm fiber length	30 mm fiber Length
10% Fiber Volume Fraction	Specimen 1	Specimen 3
20% Fiber Volume Fraction	Specimen 2	Specimen 4

The prepared material is in the form of a plate of dimensions of 290 x 290 x 3mm dimensions. These plates have to be fabricated or cut into smaller dimensions in order to undertake our desired mechanical tests. The fabrication of material is done using Switch – board cutting machine. As given in figure 4.



Figure 4 Vinyl Ester Polymer Composites Reinforced with Banana Fibers laminates

D. Testing methods

The material testing was done at LMP R&D Laboratory, Erode. The testing methods proposed for our fabricated composite materials are Tensile test, Water Absorption test, Impact test. The specimens were declared according to various ASTM standards as mentioned in table 2..

Table 2 ASTM Standards

Tests Performed	ASTM Standards	Specimen sizes
Tensile test	ASTM D-3039	250 X 250 X3mm
Water Absorption test	ASTM D-5229	20 X 20 X3mm
Impact test	ASTM D-256	65 X 13 X3mm

E. Tensile test

Tensile test is also known as tension test, where the tension is applied to the material thoroughly until it fails. As we continue to pull on the material until it breaks, we will obtain a good, complete tensile profile. The tensile testing provides us the values for Peak load, Ultimate tensile stress, and the percentage of elongation for the materials. During the research the tensile test has been conducted at the laboratory as given in figure 5.



Figure 5. Universal Testing Machine

F. Water Absorption test

Generally, the natural fibers has the ability to absorb water or moisture even after the setting of the materials. Water absorption is used to determine the amount of water absorbed under specified conditions. In this test, the specimens are weighed initially as shown in figure 6, and is allowed to soak inside water for nearly 24 hours. After, taking out from water the specimens are dried well and weighed again to compare the amount of water absorbed.



Figure 6 Weighting Machine

G. Impact test

The Impact test implemented here for this specimen is Izod impact test. The purpose of impact testing is to measure an object’s ability to resist high-rate loading. It is usually thought of in terms of two objects striking each other at high relative speeds. The Izod impact test is used for determining the impact resistance of the materials.

V. RESULTS AND DISCUSSIONS

A. Tensile test, Water absorption test and Impact test

The tensile test is carried out under Kalpak Universal Testing Machine (Capacity of 100KN), where the specimen is held between upper and lower grids and the tensile force is provided. The test is carried out until the fracture occurs at the specimen. The point of load at which the fracture occurs is known as the Peak load. The results of tensile test has been plotted in table 3.

Table 3. Tensile test results

Specimen	CS Area [mm ²]	Peak Load [N]	% of Elongation	Break Load [N]	UTS [N/mm ²]
1	75.000	155.1 35	1.540	8.976	2.070
2	75.000	592.1 02	1.947	40.800	7.897
3	75.000	609.6 82	0.767	1.501	8.132
4	75.000	238.9 72	1.720	14.970	3.188

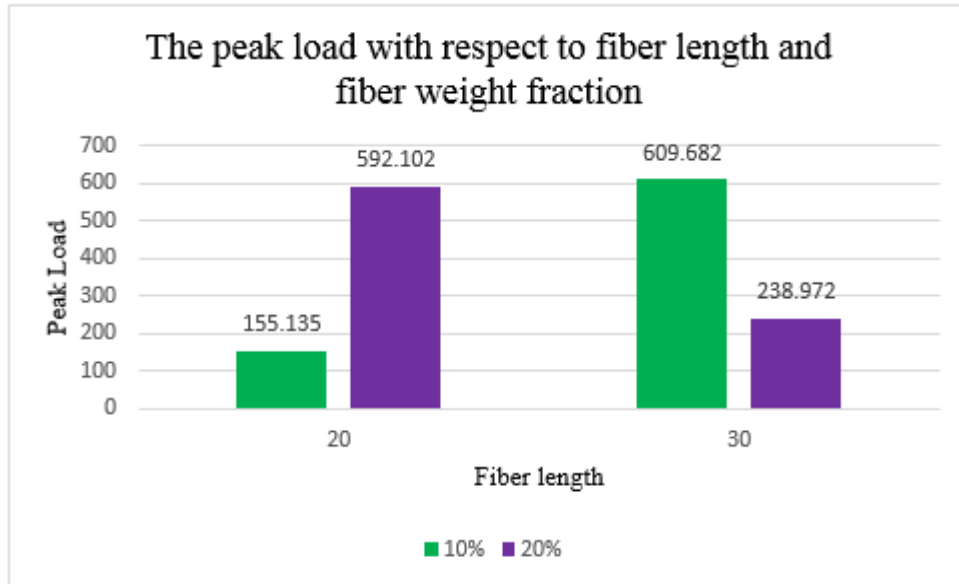

Figure 6. The peak load with respect to fiber length and fiber weight fraction

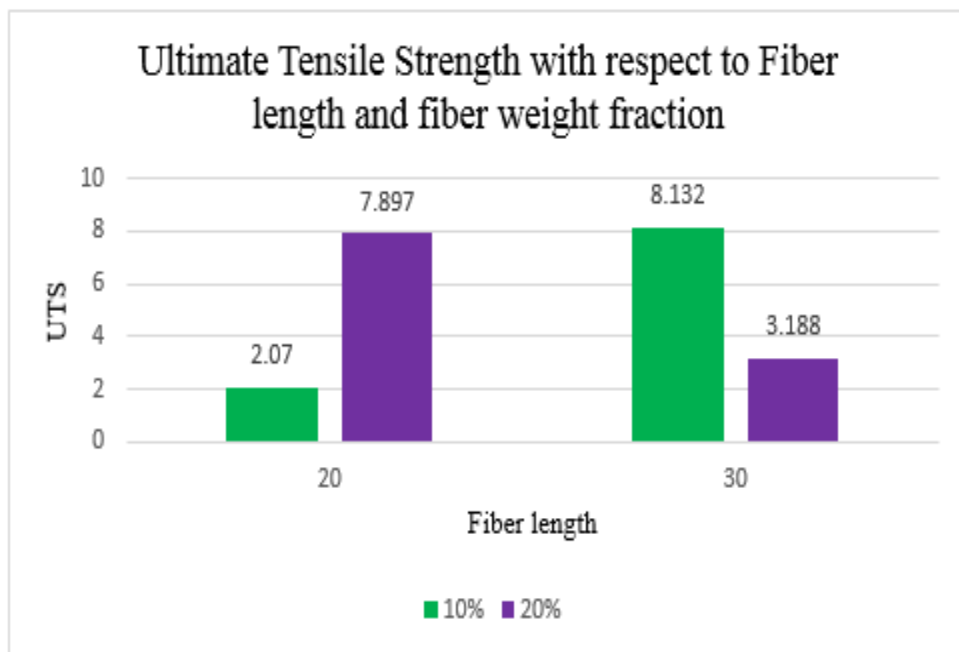

Figure 7. Ultimate Tensile Strength with respect to Fiber length and fiber weight fraction

Table 4. The results of water absorption test

Sample Number	Weight before test in grams	Weight After test in grams(24hrs)	% of water absorption
1	1.3	1.38	6.2
2	1.11	1.18	6.3
3	1.36	1.45	6.6
4	1.37	1.47	7.3

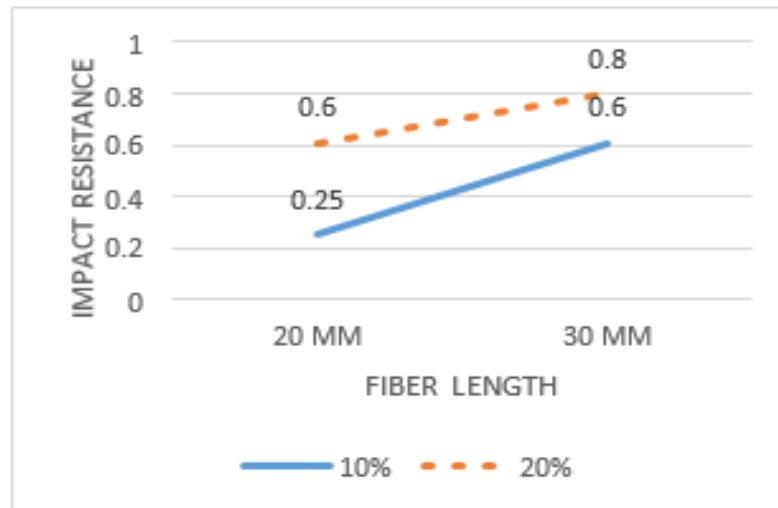

Figure 8. Graph for Fiber length Vs Impact Resistance

Table 5. The results of the Izod Impact test

Specimen	Izod impact value	Izod impact value in J/mm^2
1	0.25	0.0033
2	0.60	0.008
3	0.60	0.008
4	0.80	0.0107

- Thus, it is found that the Maximum Tensile test was found to be maximum in the specimen 3 of Composition of 10% Fiber volume and 30 mm Fiber length.
- The Impact test results were found to be increasing with Increase in Fiber volume and Fiber length and was found to be maximum at Specimen 4 with composition of 20% Fiber Volume and 20 mm Fiber Length.
- Lesser Fiber length and minimum composition of fibers lead to minimal water absorption.
- Physically appearing, the Fiber distribution with the material was found to be depending on fiber length. Longer the Fiber length, lesser the Fiber distribution. Thus, the Maximum Fiber distribution was found to be for the specimen 2 with composition of 20% Fiber weight ratio and 20 mm Fiber length.

VI. CONCLUSION

Thus, it is found to be results were appreciable for the Impact resistance values and we've got a good water absorption properties. Due to untreated fibers with alkali substances, it is found that the tensile properties were not good. Since, the vinyl ester resin is a non- corrosive material they can be used to replace the materials in the marine applications, which require Higher Impact resistance.

REFERENCES

- [1] Faruk, O., Bledzki, A.K., Fink, H., Sain, M., Bio composites reinforced with natural fibres. Prog. Polym. Sci. (2012), 1552–1596
- [2] Essabir, H., Hilali, E., Elgharad, A., E. Minor, H., Imad, A., Elamraoui, A., et al, Mechanical and thermal properties of bio-composites based on polypropylene reinforced with Nut–shells of Argan particles. Mater. Des. (2013), 442–448
- [3] Mechanics of Composite Materials by Auttar K Kaw.
- [4] A.V.Ratna Prasad K.Murali Mohan Rao and G.Nagasrinivasulu “Mechanical properties of banana empty fruit bunch fiber reinforced polyester composites” Indian journal of fiber and textile research,(2009).

- [5] JulianoFiorelli, Diego Donizetti Curtolo, Nubia G Barrero, HolmerSavastano Jr., "Particulate composite based on coconut fiber and polyurethane adhesive: An eco-efficient product", *Industrial Crops and Products*, 40(3) (2012), 69-75
- [6] SavitaDixit and PreetiVerma, "The effect of surface modification on the water absorption behavior of coir composites", *Advances in Applied Science Research*, 3(3) (2012), 1463-1465
- [7] Girisha.C. Sanjeevamurthy, GuntiRangasrinivas, "Tensile properties of natural fiber-reinforced epoxy-hybrid composites", *International Journal of Modern Engineering Research*, 2(2) (2012), 471-474
- [8] Maria Virginia Gelfusa, Pedro Vieira Gurgel da Silva, Daniel Thomazini, "Polypropylene matrix composites reinforced with coconut fibers", *Material Research*, 14(3), (2012), 360-365
- [9] P. N. E. Naveen and M Yasawi, "Experimental analysis of coir-fiber reinforced polymer composite materials", *International Journal of Science and Engineering Applications, Research*, 5(2), (2013), 4-7
- [10] T.Gopinath and R.Deepak Kumar, "Comparison of mechanical performance of hybrid vinyl- based composites reinforced with coir/sisal and sisal/kenaffibers", *International Journal of Mechanical Engineering and Robotic*, 2(1), (2013), 10-18
- [11] Onuegbu T.U, Umoh E.T. and Okoroh N.C, "Tensile behavior and hardness of coconut fiber-ortho unsaturated polyester composites", *Global Journal of Science Frontier Research Chemistry*,13(1), (2013)