

***Oscilloscope on android using raspberry pi***Vijay Patil sir<sup>1</sup>, Shivani Pagare<sup>2</sup>, Kajol Pagare<sup>3</sup>, Utkrsha Patil<sup>4</sup>*1Asst. Prof., 2, 3, 4 Student, Department of Electronics and Telecommunication Engineering,  
Sandip Foundation's, Sandip Institute of Technology and Research Center, Nashik, India.*

---

**Abstract**— *The oscilloscope on android using raspberry pi, this project is design to develop an oscilloscope by using android application. The concept is input signal which is any kind of wave such as sine wave, square wave, triangular wave etc, give it to high sampling rate and applied to ADC. The ADC (MCP3008) sends data to the raspberry pi3 model B, high speed processor. The raspberry pi will read the data on serial port and send the data to the android phone through the inbuilt Bluetooth module.*

---

**Keywords**—ADC (MCP3008), Raspberry pi 3 Model B, Android Phone,

**INTRODUCTION**

we can see now a days there are large size oscilloscope are use in which we see different waveforms and measure the frequency, Time etc, in a lab only ,Which Consumes a Lot of time and money.[1] so we can implement this project using Android...! Portable oscilloscopes in the market are very expensive, less power efficient This paper presents the design and implementation of a low cost, portable, light-weight, low power, single-channel oscilloscope, consisting of a hardware device and a software application. The device is equipped with raspberry pi3 model B.[2] which consist a Bluetooth module to provide connectivity to a device with Bluetooth, running the Android operating system (OS), in order to display the waveforms. Android OS is selected because there are a more number of Android device users and most of these devices satisfy the requirements of the oscilloscopes software application. The Software application developed for Android receives the data transmitted from the hardware device and plots the waveform according to the display settings configured by the user. These display configurations are transmitted to the hardware device once they are set by the user, and are used by the hardware device to set the sampling rate and the values of samples.



**Fig 1: general cathode ray oscilloscope**

**SYSTEM OVERVIEW**

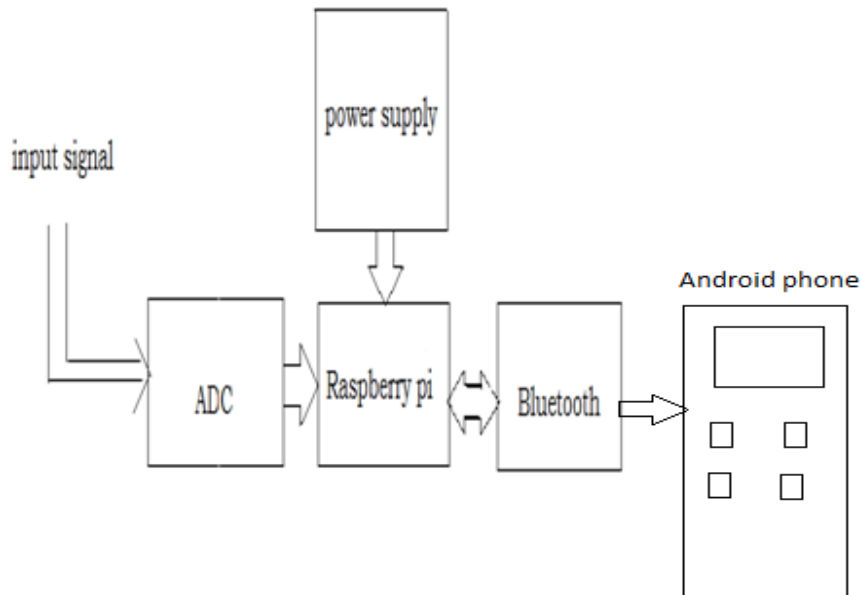

**FIG 2: BLOCK DIAGRAM**

**Block Diagram Explanation:** in this block diagram we give the signal to the ADC IC which is (MCP3008).this mcp IC has 4 pins that is MIMO(Multiple Input Multiple Output), MISO(Multiple Input Single Output), CS(Chip Select), CLK(Clock). this 4 pins are connected to raspberry pi. Raspberry pi has 40 GPIO pins. but out of which we required only 4 pins to connected this signal i.e.(pin no.19 is use for MOSI, pin no. 21 is use for MISO, pin no.23 is use for CLK and pin no.24 is use for CS).Raspberry pi has inbuilt Bluetooth module, therefore we can transmit the waveform through this Bluetooth module. which is already present in android phone. therefore instead of using very large size of oscilloscope we can use android phone so with the help of android application we can transmit or receive the signal through the wireless Bluetooth. and as we know the now a days the growth of android phone is rapidly increases so its easily available and the main things is that it support the hardware. Therefore we can connect the Raspberry pi very easily to the android phone.



**FIG 3: RASPBERRY PI 3 MODULE B**

**Working of Raspberry pi:** in raspberry (BCM2835 SoC) many inbuilt function is available such as HDMI port, Bluetooth,40 GPIO pins, USB ports, SD cards etc. in our project ADC(MCP3008)IC is send output signal to raspberry pi 40 GPIO pin. out of these 40 GPIO pin we required only 4 pins of raspberry pi. Which is pin no.19 for MOSI, pin no. 21for MISO, pin no.23 for CLK and pin no.24 for CE. Raspberry pi accept the input and with the help inbuilt Bluetooth module.

through the wireless technique we can see the waveform on android phone by inbuilt Bluetooth .and in future if we want to see waveform on our PC or TV then through this inbuilt HDMI port of raspberry pi it will be possible.

#### ALGORITHM:

**Step1-** first we give the input signal to the ADC (MCP3008). it may be any kind of signal such as sine wave, triangular wave, square wave etc.

**Step2-** MCP3008 ADC receives this input signal it has SPI protocol. Means this SPI protocol have 4 pins. i.e. MISO, MOSI, CE, CLK. these 4 pins connected to Raspberry pi3 module.

**Step3-** power supply gives 3.3v supply to raspberry pi. In power supply use two IC which is LM7805 and 1117. LM7805 provide 5V output and 1117 provide 3.3V output

**Step4-** ADC signal give to raspberry pi. For programming of raspberry pi we used the raspbian and wiring pi library

**Step5-** It has 40 GPIO pins. Out of these 40 pins, we required only 4pins to read the signal.

**Step6-** we use android studio software for the android application. With the help of these app we can done android programming

**Step7-**Setup of android studio-Before any work can begin on the development of Android application, necessary step to install the requisite components for Android Application development on Windows, Mac OS X and Linux based systems

**Step8-**for installing the android studio we have to first install java development kit The Android SDK was developed using the Java programming language. Similarly, Android applications are also developed using Java. As a result, the Java Development Kit (JDK) is the first component that must be installed.

**Step9-**So these pins are read the signal. And with the inbuilt Blue-tooth module, signal transmitted to android application. And the android phone displays the waveform on screen.

#### RESULT

In android phone we can create our own application. With the help of this android application we can see the output Waveform. Through the wireless Bluetooth we can interface Raspberry pi and android phone. This application also shows the frequency and voltage of the signal.

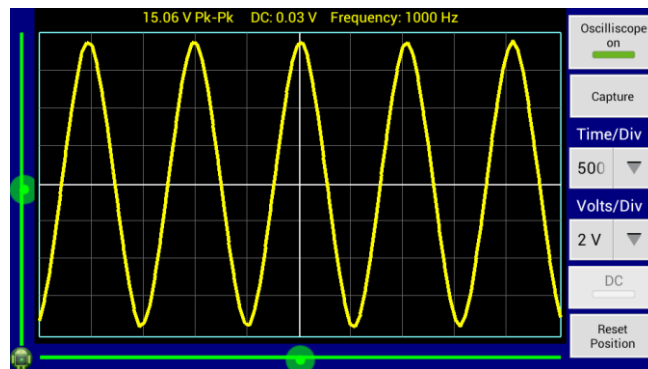

**FIG 4: OUTPUT WAVVFORM**

#### ADVANTAGES FOR ANDROID PHONE:

- supported by some hardware manufactures and more to come in future
- we can modify the android program at any time

#### **DISADVANTAGES:**

- limited Bluetooth range
- no inbuilt ADC available in Raspberry pi

#### **CONCLUSION**

in this way implement the one android application so we can create one objective i.e. with the help of these system we can transmit or save different types of waveform, like sine wave, triangular wave, square wave, etc. we can create our own android app so we can change the program at any time. The hardware device includes circuitry to get the input voltage signals and a raspberry pi module.

#### **REFERENCES**

- [1] Yus “Android Bluetooth Oscilloscope.” (2010, sep.23).
- [2] Kalyani Ganvir and Hemant Waghmare, “Oscilloscope on Android Phone”, Volume 3, Issue 4 ISSN:2277 128X, 2013.
- [3] Bhagyashree D. Hatwar, Prof. Amol C. Wani, Wireless Oscilloscope Powered by Android, International Journal of Emerging ISSN 2250-2459, ISO 9001:2008 certified Journal, Volume 4, Issue 7, July 2014.
- [4] Android Developers, “Bluetooth Socket”, Mar. 5, 2013.
- [5] A Formal Specification of an Oscilloscope, Norman Delisie and David Garlan, Tektronix, 07407459/90/0900/0029/\$01.00,1990 IEEE.